



Amerex Instruments, Inc.

HICLAVE

HV-SERIES AUTOCLAVES

(HV-25, HV-50, HV-85, and HV-110)

OPERATION MANUAL

*Before using this Autoclave, please read this manual
and follow all Safety Rules and Operating Instructions.*

**3951C Industrial Way Concord, CA 94520
(925) 299-0743 / (888) 263-7392 · Fax:(925) 299-0745
marketing@amerexinst.com · www.amerexinst.com**

- We would like to express our gratitude for your purchase of our autoclave. This manual covers the operation method and a simple maintenance method for the Autoclave HV-25/50/85/110 you now own. We hope that owing to your proper handling the autoclave can demonstrate its full performance and that you will make regular use of it for a long time.
- For optional equipment (Digital printer, Floating sensor, Cooling unit, Automatic water supply unit), if any, read the attached instruction manuals for the options.
- Please check whether or not the product conforms to your order and confirm that it was not damaged during transportation. Should it be damaged or out of order, please contact our authorized distributor in your region.

- ① No part of this document may be reproduced without permission.
- ② The contents of this document are subject to change without notice.
- ③ This document has been carefully compiled. If you have any questions or necessary information uncovered in the document, please contact our authorized distributor in your region.

Read Carefully Before Using

- Determine the handling person responsible of this product.
- In this manual the following headings are applied to items to which great attention should be given:

 **WARNING :** Precaution indicating an imminent dangerous situation which if not avoided may lead to death or serious injury.

 **CAUTION:** Precaution indicating a dangerous situation which if not avoided may lead to moderate or slight injury.

 **IMPORTANT:** Indicates items you are strongly advised to obey.

 **NOTE:** Items that will aid in proper operation of the equipment.

 **WARNING:**

- Never use the autoclave to sterilize any of the following hazardous materials or substances with alkali content. Sterilization of such objects can cause explosion, corrosion of the working chamber or chamber piping, and deterioration of gaskets.

List of Hazardous Materials

① Explosive substances

- Nitroglycol, nitroglycerin, nitrocellulose, and other explosive nitric esters.
- Trinitrobenzene, trinitrotoluene, picric acid, and other explosive nitro compounds.
- Peracetic acid, methyl ethyl ketone peroxide, benzoyl peroxide, and other organic peroxides.

② Ignitable substances

- Metallic lithium, potassium, sodium, yellow phosphorous, phosphorus sulfide, and red phosphorus.
- Celluloids, calcium carbide (carbide), lime phosphide, and magnesium powder
- Aluminum powder, magnesium powder, and metallic powders other than aluminum powder
- Sodium dithionite (or sodium hydrosulfite)

③ Oxidizing agents

- Potassium chlorate, sodium chlorate, ammonium chlorate, and other chlorates
- Potassium perchlorate, sodium perchlorate, ammonium perchlorate, and other perchlorates.
- Potassium peroxide, sodium peroxide, barium peroxide, and other inorganic peroxides
- Potassium nitrate, sodium nitrate, ammonium nitrate, and other nitrates
- Sodium chlorite and other chlorites
- Calcium hypochlorite and other hypochlorites

④ Flammable substances

- Ethyl ether, gasoline, acetaldehyde, propylene oxide, carbon disulfide, and other substances whose flash points range from -30 to 0°C.
- Methanol, ethanol, xylene, benzyl acetate (or amyl acetate), and other substances whose flash points range from 0 to 30°C.
- Kerosene, gas oil, turpenine oil, isopentyl alcohol (or isoamyl alcohol), acetic acid, and other substances whose flash points range from 30 to 65°C.

⑤ Flammable gas (hydrogen, acetylene, ethylene, methane, ethane, propane, butane, and other substances that are gases at a temperature of 15°C under 1 atmospheric pressure.)

- When liquid with salt water and much salinity of salt agar etc. spills in the chamber, blowing, discharge water in the chamber and wipe up drop of water around the lid gasket beautifully. It causes the corrosion of the chamber and the piping when leaving just as it is
- Check that the pressure is below "0Mpa" before opening the lid.

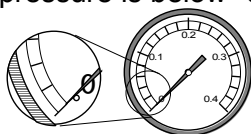

- Absolutely do not attempt to remodel or alter this product.
- Do not use this product near explosive gas, as a few parts used are not explosion proof structure.

 **CAUTION:**

- Foreign matter (metals, liquid) may enter through the vent hole. Operating the equipment with such foreign matter inside may cause trouble with the equipment, fire or electric shock.
- Do not forcibly bend, twist, tie or extend the power cord. Do not place heavy objects on the cord. A damaged cord or exposed wire can cause fire or electric shock.
- Never connect the power cord to a power supply other than one of the rated voltage. Connection to such a power supply can cause fire or electric shock.
- If grounded socket is unavailable, ground the equipment using a separate ground wire before connecting the power cord to the power source.
- Never ground to a gas pipe or vinyl chloride water service pipe.
- Do not pour anything except for water.
- Raise the lid slowly. When an impact is added to the lid, there is fear which the hinge of the lid damages.
- Do not use the autoclave for the purpose other than sterilization and agar preparation (dissolution).
- Close the lid after confirming that no foreign matter is adhering to the section contacting the lid gasket. Foreign matter in this section can cause vapor leaks.
- When using a waste processing bag or other kind of bag and disinfecting, place the bag in the metal mesh holder and then insert it into the chamber. Using the bag “as is” can cause excessive temperatures, pressures, lack-of-water, etc.
- Be careful not to pinch your hands when closing the lid.
- Do not put your face or hands close to the chamber when lifting the lid after operations are complete; steam will gush out of the chamber.
- The lid, chamber, gasket and panel are extremely hot immediately after the completion of operation. Do not touch the equipment or you may get burned.
- Put on heat insulating gloves before removing a substance from the chamber. Do not put hands into the chamber until the steam has been vented.
- Some time is required for liquids to cool. Be sure to check that the temperature has dropped sufficiently before unloading a liquid from the chamber or burns can result.
- Do not unload the exhaust bottle or drain the chamber when the chamber is under pressure. Boiling water or steam may gush out causing burns.
- Do not remove the exhaust bottle before water in the bottle has sufficiently cooled.

- Do not throw the used battery into the fire, it may burst.
- If any abnormality occurs (e.g. abnormal sounds, smells, smoke), immediately shut the power off. After checking to see that the abnormal condition does not continue, call our authorized distributor in your region.
- If the display reading changes between the steps, turn the POWER switch off then on again. If the problem continues, turn the power switch off and call our authorized distributor in your region.

How to Read this Manual

- This operation manual consists of the following sections covering the information required for proper operation of the Autoclave HV-25/50/85/110:

Chapter 1. What is the Autoclave HV-25/50/85/110?

This section describes the uses and features of the product and the names and functions of its parts.

Chapter 2. Installation

This section explains where the equipment should be installed and how to install it. The product incorporates precision parts, so be sure to follow the instructions covered in this chapter.

Chapter 3. Operation Method

This section illustrates how to change various set values, and describes operations before starting the equipment and after automatic operation. This section also covers the display and performance of the equipment during automatic operation.

Chapter 4. Maintenance and Service

This section explains the methods for draining water from the exhaust bottle or chamber, cleaning the body of the equipment, and parts replacement.

Chapter 5. Specifications

This section includes dimensions, power consumption and working range of the product. Refer to this section as is required.

Chapter 6. Troubleshooting

This section covers troubleshooting procedures for the product. If you encounter a problem, read this section first.

Appendix

This section contains information on the warranty and a glossary of terms that appear in the manual. Please refer to this section when necessary.

Contents

Introduction	1
Revisions.....	1
Read Carefully Before Using	2
How to Read this Manual	5
Contents	6
Chapter 1. What is the Autoclave HV-25/50/85/110?	7
1. Product Uses	7
2. Product Features	7
3. Names and Functions of Each Part	7
Chapter 2. Installation	9
1. Installation Instructions	9
2. Installation Procedure	10
Chapter 3. Operation Method	13
Basic Operation Method	13
1. Turning "ON" POWER Switch	14
2. Pouring Water	14
3. Loading Substance	15
4. Selecting Mode (Process)	16
5. Changing Set Values (Registering of Values by Customer)	18
6. Checking and Correcting the Clock Time	20
7. Checking and Setting of Turn-on Timer	21
8. Starting Operation	23
9. Unloading	25
10. After Completion of Operations	25
11. To Interrupt Operation	26
12. If Power Supply is Cut Off during Operation	26
13. Operation of Cycles	26
Chapter 4. Maintenance and Service	30
1. Draining Exhaust Bottle	30
2. Draining Chamber	31
3. Cleaning Chamber	31
4. Cleaning Body	32
Chapter 5. Specifications	33
Chapter 6. Troubleshooting	35
1. Error Detection (Alarms)	35
2. Early Troubleshooting	37

Chapter 1. What is the Autoclave HV-25/50/85/110?

1. Product Uses

- The product is used to sterilize substances which can withstand high temperature and high pressure steam such as tools of glass, ceramic, metal or rubber, water, media, reagents and liquid medicines (Mode 1 – 3) .
- The product is also used to liquefy media (Mode 4).

2. Product Features

- This product is equipped with a cover for the lid that may be heated at high temperature during use.
- The product incorporates an automatic timer which permits you to begin operation at any desired time within a period of one week.
- The product is provided with a variety of modes of operation. The modes are divided into two broad categories: Sterilization-warming mode and liquefaction mode. If you do not take out the sterilized medium immediately, then select the sterilization-warming mode, and coagulation is prevented. To liquefy a coagulated medium, use the liquefaction mode.
- This autoclave can be set to automatically exhaust % inside the chamber at a desired rate (exhaust valve aperture) after sterilization is over.
- Optional equipment (printer, floating sensor, cooling fan, automatic water supply equipment) can be installed onto the product at a later date.

3. Names and Functions of Each Part

● Outer View of Body

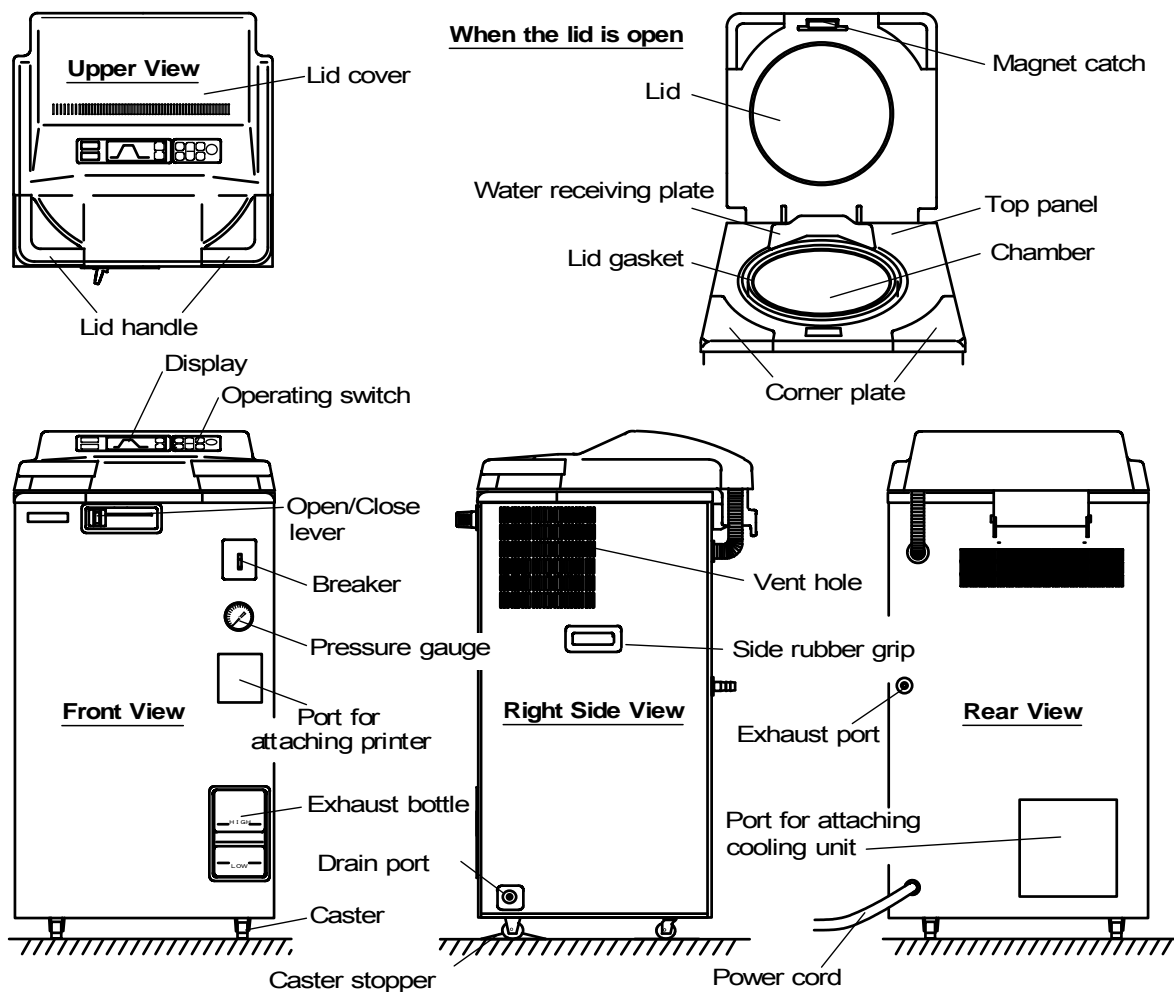

● Display and Operation Switches

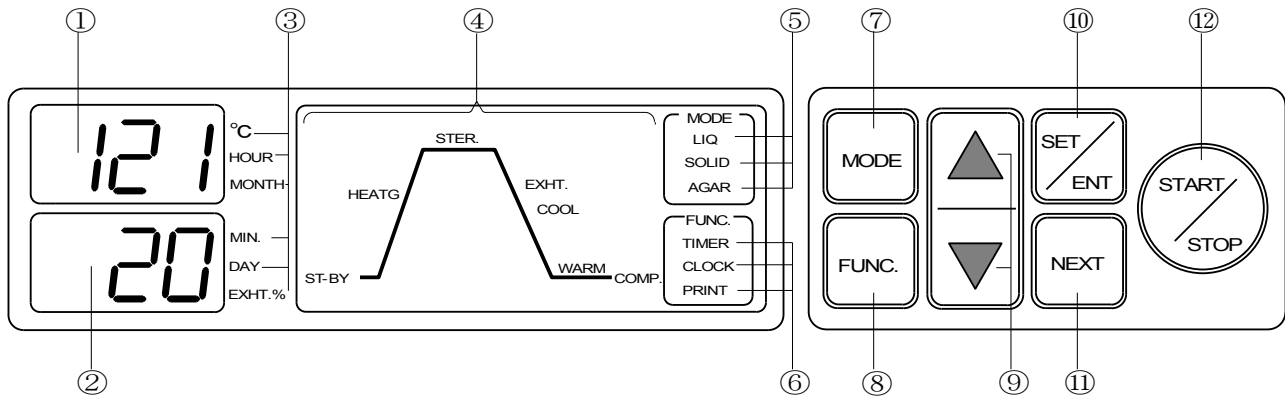

① Digital Display (Temperature, Time of Day, Error)

The digital display indicates the set temperature, current time and pre-selected time of day when the equipment is in a standby state and it indicates the temperature in the working chamber during operation. When a problem occurs and an error is detected, the display indicates the error.

② Digital Display (Time, Time of Day, Exhaust %)

The digital display indicates the set time and the set exhaust % , current time, and pre-selected time of day when the equipment is in a standby state and it indicates remaining time before the completion of sterilization.

③ Unit Display (°C, HOUR, MONTH, MINUTE, DAY, EXHT. , %)

A unit corresponding to a current digital display illuminates.

④ Cycle Display (ST-BY, HEATG, STER., EXHT, COOL, WARM, COMP.)

All the steps included in the selected mode illuminate, and the current Cycle blinks. (**COOL** display is illuminated when the optional equipment has been installed.)

⑤ Mode Display (LIQ, SOLID, AGAR)

The operation/action of the selected mode lights up.

⑥ FUNC. Display (TIMER, CLOCK, PRINT)

The **TIMER** display illuminates when you set the turn-on timer or check the contents of its setting, and blinks when you complete setting the timer. The **CLOCK** display lights up when the operator checks or changes the time, and blinks when the backup battery has gone dead. (The **PRINT** display illuminates when the optional equipment has been installed.)

⑦ MODE Switch

This switch is used to select the mode and to check a set temperature or time, or exhaust % .

⑧ FUNC. Switch

Used to check the set values for each function.

⑨ SET VALUE INCREASE/DECREASE Switches (▲, ▼)

Increase or decrease the set values.

⑩ SET/ENT Switch

Used to change a set value.

⑪ NEXT Switch

Selects the item for which you wish to change the setting.

⑫ START/STOP Switch

Used to start or stop operation.

Chapter 2. Installation

! CAUTION :

- If the equipment is installed in a place which is 800m or higher than sea level (i.e. under low pressure in mountainous areas), the settings must be changed. In this case, be sure to contact our authorized distributor in your region. Do not use the equipment before changing.
- When transporting the equipment, close the lid and slide the open/close lever to **LOCK** side (left end) to prevent the lid from opening.
- When moving the lid, do not hold it by the handle, otherwise the lid may become difficult to close.

1. Installation instructions

- ① Avoid installing the equipment in a place where its body may be exposed to water or chemicals, or where corrosive and explosive gases may be produced nearby.

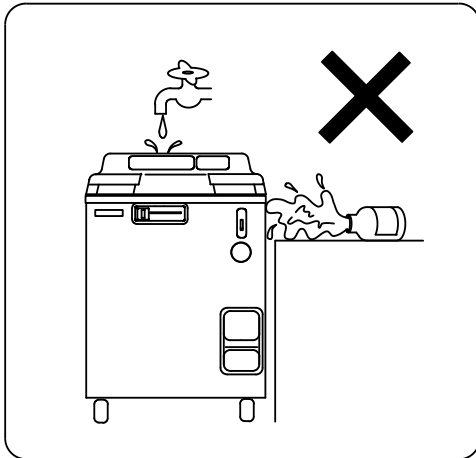

- ② Avoid installing the equipment in a place which is exposed to high humidity, direct sunlight or much dust.

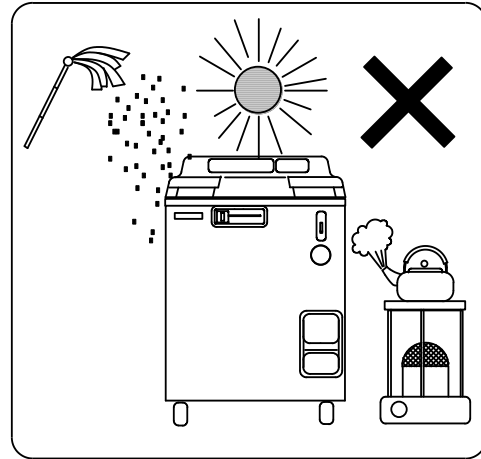

- ③ Avoid placing the equipment directly under a fire detector. If you open the lid immediately after completion of operation, steam comes out of the working chamber, and may activate the detector.

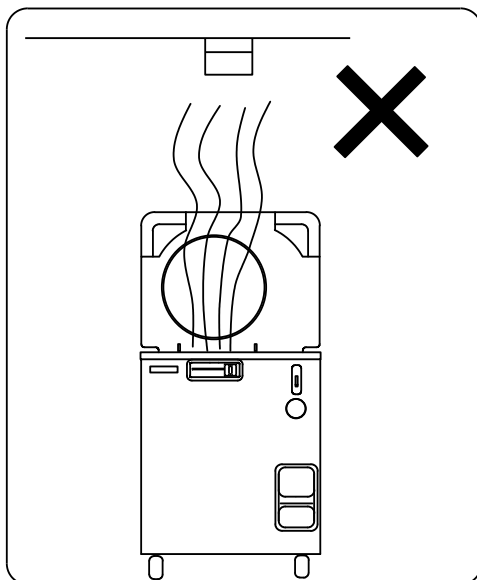

- ④ Arrange the equipment with a clearance of 10 cm or wider on the right side and 12 cm or wider on the rear side to prevent the vent hole from being blocked.

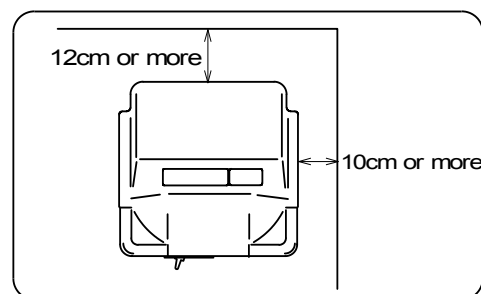

- ⑤ Avoid installing the equipment with its rear side located near outlets or electrical appliances as steam comes out of the exhaust port on the rear.
- ⑥ Avoid an installation place which is subject to impact or vibration.
- ⑦ Place the unit in a level, firm place.
- ⑧ Avoid installing in a place which is subjected to a room temperature of 5 °C or below or 35 °C or above.

2. Installation Procedure

① Move the unit to the place of installation.



CAUTION :

- In transporting the equipment, put the lid on and slide the open/close lever to the end of the close side to prevent the lid from opening.
- When moving the lid, do not hold it by the handle, otherwise the lid may become difficult to close.

② Put the body on the caster stoppers to prevent the body from accidentally moving.

- Anchor the body as described in the following.

(1) Set the stopper the specified distance from walls.

Specified distance L = **HV-25**... .. 49cm or more

HV-50... .. 55cm or more

HV-85/110..... 67cm or more

(2) Push the body until the front casters roll onto the stopper.

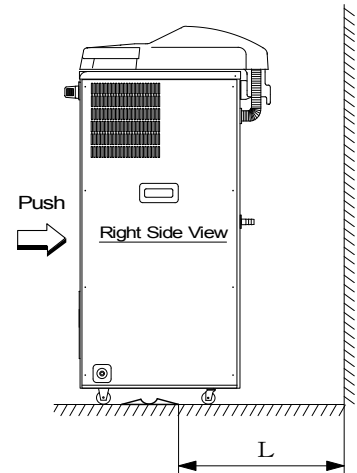

③ Connect the power cord to a rated power supply.

- Reliably ground the earth cable.



WARNING:

- Do not forcibly bend, twist, tie, or extend the power cord. Do not place heavy objects on the cord. A damaged cord or exposed wire may cause fire or electric shock.
- Never connect the power cord to a power supply with a voltage other than the rated voltage. Connection to such a power supply may cause fire or electric shock.
- If not plugging the sterilizer into a grounded socket, ground the equipment separately before connecting it to the power source.
- Never ground to a gas pipe or vinyl chloride water service pipe.

- Connect with the rated power supply, and ground the Green/Yellow wire.

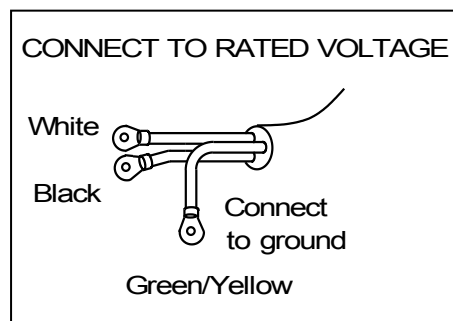

	AC110V	AC120V	AC220V	AC230V	AC240V
HV-25	14A or more	13A or more	7A or more	7A or more	7A or more
HV-50	19A or more	17A or more	10A or more	9A or more	9A or more
HV-85			14A or more	14A or more	13A or more
HV-110			19A or more	18A or more	17A or more

④ Pour water into the exhaust bottle.

- Add water to the exhaust bottle as described below.

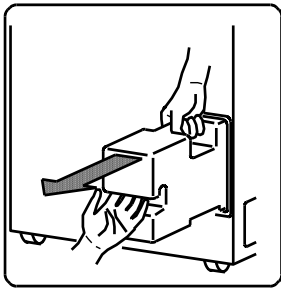

(1) Unload the exhaust bottle from the body.

- Pull the bottle outwards until the top handle can be grabbed securely. Lift the bottle out of the autoclave using this handle.

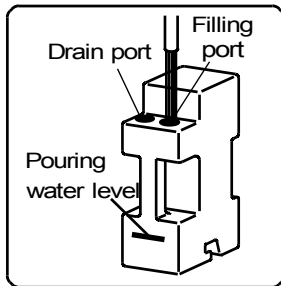

(2) Pour water into the bottle through the water filling port. Fill water to the reference line level.

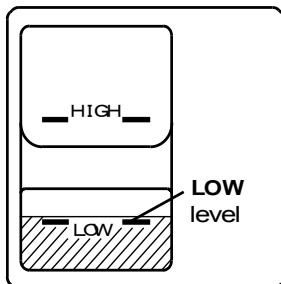

(3) Check to make sure that the water level is at **LOW** level (the lowest water level).

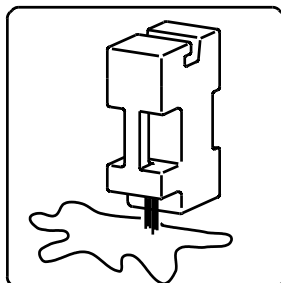

- If too much water has been poured in, then place the bottle in a level sink with the side of the water filling and drain ports facing downwards. Any excessive water is drained automatically until the water level is lowered to the **LOW** level.

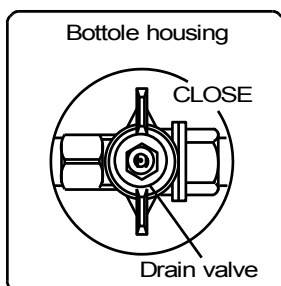

(4) Check to see that the drain valve, located at the bottom of the exhaust bottle housing area, is closed.

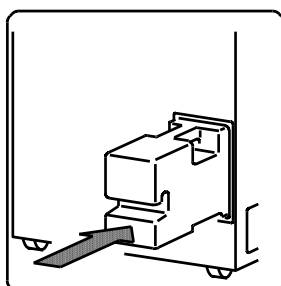

(5) Load the bottle into the area.

- Be sure to push the bottle to the end, or else an error (**E r E**) will occur.

- ⑤ Referring to “**Chapter 3, Operation Method**”, open the lid and take out the accessories.
- ⑥ Place the bottom plate in the chamber.
- ⑦ Steam is apt to emit from the exhaust port located at the rear of the body.
Therefore, install the exhaust hose and the drain bottle in the following manner:
(1) Attach the strap and clamp loosely in use of the screw attached to the body.
(2) Pass the exhaust hose through the strap. Be careful not to clog the hose by folding.
(3) Put the hose tip about 5cm into the drain bottle, and tighten the strap.
[N.B.] Pour out the water from the drain bottle so that the hose tip does not touch the water.

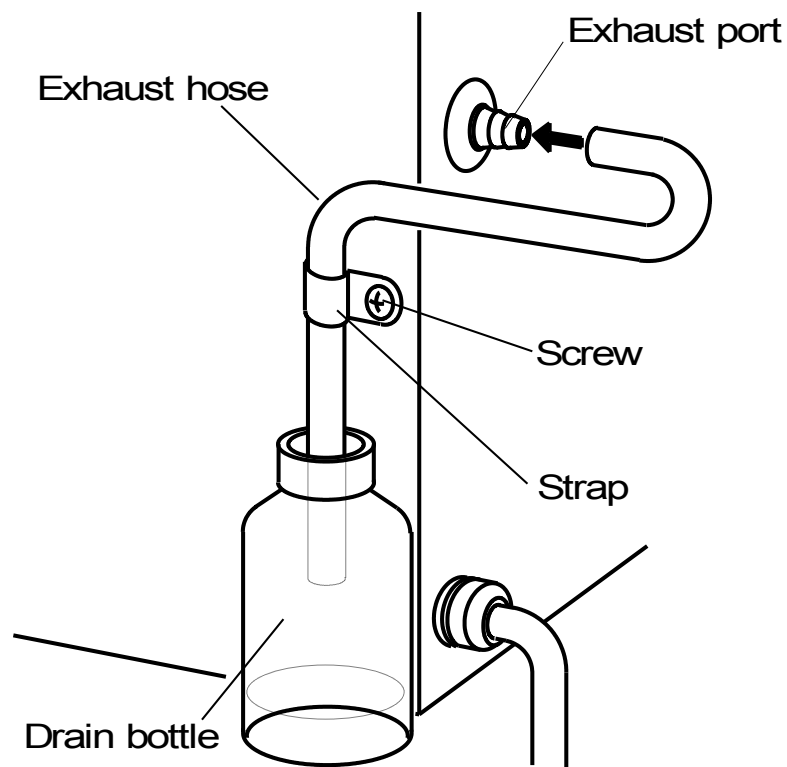

Chapter 3. Operation Method

Basic Operation Method

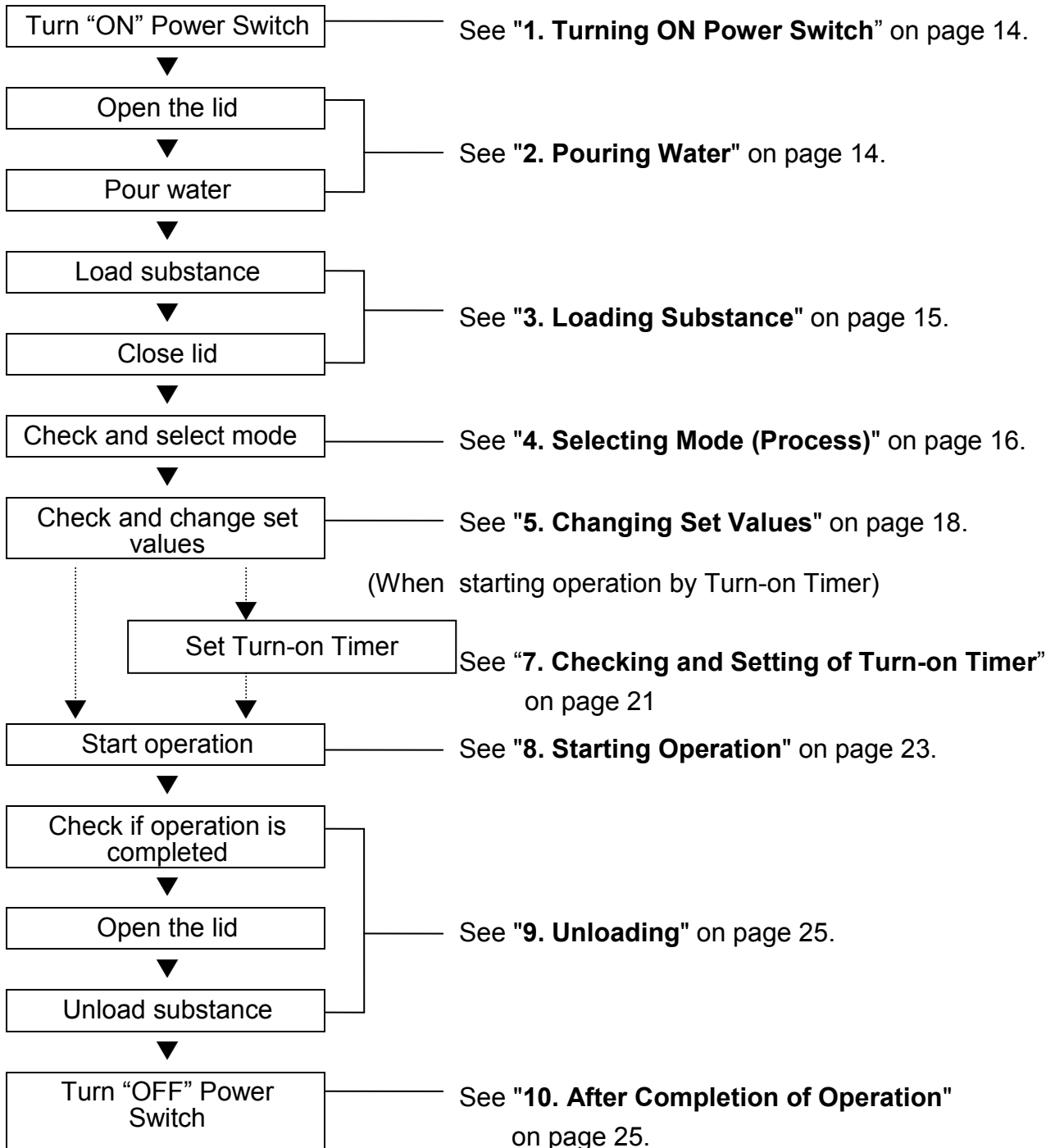

1. Turning "ON" POWER Switch

- ① Turn ON the POWER switch at the front of the body.
When the open/close lever is set to "LOCK" (left side), Mode number is indicated on the display. After 2 seconds, the display indication changes into setting values, and the autoclave is ready in this state. When the open/close lever is set to "UNLOCK" (anywhere other than on the left side), "Lid" is shown on the display.

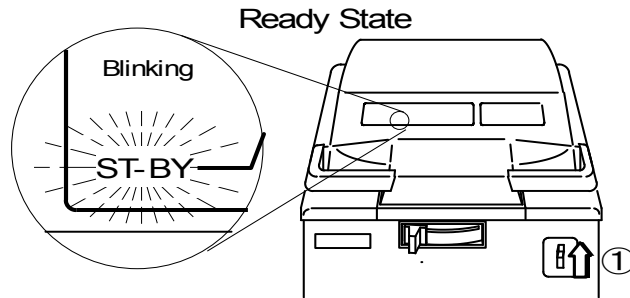

NOTE:

- If the operation switches and the lock / unlock lever are left un-operated for **30 minutes**, the power saving function starts to work so that the display board blackens except for dots blinking at the temperature zone. For reviving the display, please press any of the operation switches.

2. Pouring Water

CAUTION:

- Do not pour anything except for water.
- Raise the lid slowly. When an impact is added to the lid, there is fear which the hinge of the lid damages.

IMPORTANT :

- In operation of **UNLOCK/LOCK** lever, never fail to put **POWER** switch **ON**.

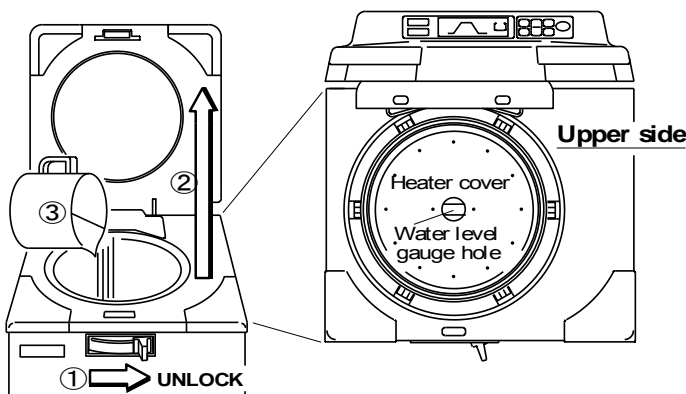

- ① Slide the open/close lever to the **UNLOCK** side (right end).
- ② Grab the handle and, lift the lid as shown in the figure below.
- ③ Pour water through the opening of the chamber until you can see water through the hole at the center of the Heater cover.
 - The **HV-25** requires **1.5 liters** or more of water; the **HV-50**, **2liters** or more; the **HV-85**, **4 liters** or more; and the **HV-110**, **5 liters** or more. It is also required to pour water for Mode 4 (**AGAR**).

3. Loading Substance



CAUTION:

- Be careful not to pinch hands when closing the lid.
- Close the lid after confirming that no foreign matter is adhering to the section contacting the lid gasket. Foreign matter in this section may cause vapor leaks.
- When using a waste processing bag or other kind of bag and disinfecting, place the bag in the metal mesh holder and insert it into the working chamber. Using the bag “as is” can cause excessive temperatures, pressures, lack-of -water, etc.



IMPORTANT :

- Keep the lid open for 15 minutes or more between operations when the equipment is operated continuously. Check to see that the temperature in the chamber is 50°C or below before starting the next operation (operating the open/close lever).
- Be sure to use the Heater cover.

- ① Place the substance to be sterilized into the chamber.
- ② While having the handles, lift up the lid cover.
- ③ Press the front-center portion of the lid cover down until the magnet is attracted to the magnet catch.
- ④ While pressing down the lid cover, slide the open/close lever to the **LOCK** side (the left end).

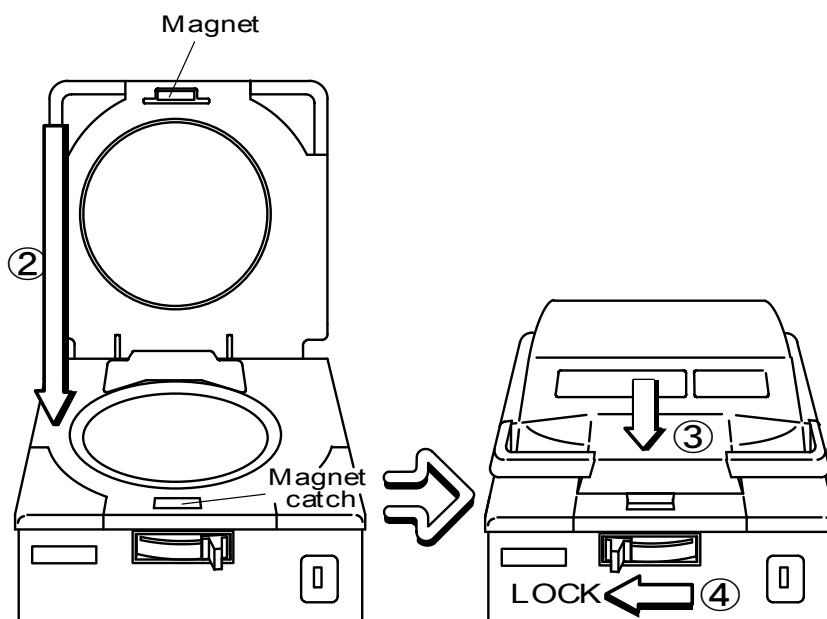

NOTE:

- When sterilizing an empty deep container, lay the container on its side in the chamber so that it will be permeated with steam. An upright position may cause insufficient sterilization.
- If a waste disposal bag is used in sterilization, open the bag far enough that the bag is not in contact with the inside surface of the chamber. Insufficient sterilization may be caused if the bag is closed during sterilization. When the bag is opened excessively, steam is prevented from circulating in the chamber. This may also result in insufficient sterilization.
- Do not pile specimens on top of one another. When the chamber is overly packed, steam fails to penetrate to all points, resulting in incomplete sterilization.
- In sterilizing liquids such as chemicals and media, pay attention to the quantity of the liquid in relation to its container. For an Erlenmeyer flask, the amount of chemical should be approx. 3/4 of the capacity of the container; for a test tube, the appropriate quantity of chemical is approx. half of the capacity of the container. Too much chemical may result in overflow from the container during the temperature rising or cooling process.
- Use container caps that are loose fitting and allow the passage of air. Containers may break if venting is not possible.
- In the case of dissolution of agar media, its quantity should be 2 liters or less per container. Two liters or more of agar medium may not be completely dissolved.
- Use the DURHAM TEST TUBE (Sample tube) with 6mm caliber or more. At the DURHAM TEST TUBE (Sample tube) with less than 6 mm caliber, air bubble sometimes remains.

4. Selecting Mode (Process)

- The following modes are programmed in the microcomputer. Select a mode suitable for your purpose.

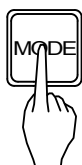

① Press the **MODE** switch.

- Each time the switch is pressed, the current mode repeatedly changes from Mode 1 to Mode 2, 3, 4, 1... in sequence.
- After 2 seconds of Mode number indication, the setting values are displayed.

Mode	Application
1	Sterilization of agar medium (warmed for the prevention of coagulation after sterilization).
2	Sterilization of liquid, such as water, media, reagent, and liquid medicines, that withstand high temperature, high pressure steam.
3	Sterilization of tools of glass, ceramic, metal or rubber that withstand high temperature, high pressure steam and abrupt depressurization during the exhaust process.
4	Dissolution of Agar

Mode 1	Cycle Display	Initial Set Value				Mode Display
		Sterilization Temperature	Sterilization Time	Warming Temperature	Exhaust %	
	HEATG → STER. → EXHT. (Varied) → WARM	121°C	20 minutes	50°C	10 %	LIQ
	<div style="display: flex; align-items: center;"> <div style="border: 1px solid black; padding: 5px; margin-right: 10px;">50 °C</div> <div style="margin-right: 10px;">Alternate display</div> <div style="font-size: 2em;">↔</div> </div> <div style="border: 1px solid black; padding: 5px; margin-top: 5px;">10 EXHT.%</div>	<div style="display: flex; align-items: center;"> <div style="border: 1px solid black; padding: 5px; margin-right: 10px;">121 °C</div> <div style="margin-right: 10px;">MIN.</div> <div style="border: 1px solid black; padding: 5px;">20</div> </div>				
Mode 2	Cycle Display	Initial Set Value				Mode Display
		Sterilization Temperature	Sterilization Time	Warming Temperature	Exhaust %	
	HEATG → STER. → EXHT. (Varied)	121°C	20 minutes		10 %	LIQ
	<div style="display: flex; align-items: center;"> <div style="border: 1px solid black; width: 60px; height: 40px; margin-right: 10px;"></div> <div style="margin-right: 10px;">Alternate display</div> <div style="font-size: 2em;">↔</div> </div> <div style="border: 1px solid black; padding: 5px; margin-top: 5px;">10 EXHT.%</div>	<div style="display: flex; align-items: center;"> <div style="border: 1px solid black; padding: 5px; margin-right: 10px;">121 °C</div> <div style="margin-right: 10px;">MIN.</div> <div style="border: 1px solid black; padding: 5px;">20</div> </div>				
Mode 3	Cycle Display	Initial Set Value				Mode Display
		Sterilization Temperature	Sterilization Time	Warming Temperature	Exhaust %	
	HEATG → STER. → EXHT. (Fixed)	121°C	20 minutes			SOLID
	<div style="display: flex; align-items: center;"> <div style="border: 1px solid black; width: 60px; height: 40px; margin-right: 10px;"></div> <div style="margin-right: 10px;">Alternate display</div> <div style="font-size: 2em;">↔</div> </div> <div style="border: 1px solid black; padding: 5px; margin-top: 5px;"></div>	<div style="display: flex; align-items: center;"> <div style="border: 1px solid black; padding: 5px; margin-right: 10px;">121 °C</div> <div style="margin-right: 10px;">MIN.</div> <div style="border: 1px solid black; padding: 5px;">20</div> </div>				
Mode 4	Cycle Display	Initial Set Value				Mode Display
		Dissolution Temperature	Dissolution Time	Warming Temperature	Exhaust %	
	HEATG → WARM	100°C	10 minutes	50°C		AGAR
	<div style="display: flex; align-items: center;"> <div style="border: 1px solid black; padding: 5px; margin-right: 10px;">50 °C</div> <div style="margin-right: 10px;">Alternate display</div> <div style="font-size: 2em;">↔</div> </div> <div style="border: 1px solid black; padding: 5px; margin-top: 5px;"></div>	<div style="display: flex; align-items: center;"> <div style="border: 1px solid black; padding: 5px; margin-right: 10px;">100 °C</div> <div style="margin-right: 10px;">MIN.</div> <div style="border: 1px solid black; padding: 5px;">10</div> </div>				

5. Changing Set Values (Registering of Values by Customer)

- To change set values (sterilization temperature, sterilization time, warming temperature, opening of exhaust valve, dissolution temperature, dissolution time), follow the steps below: Settings cannot be changed while the chamber is running except if wanting to change the exhaust rate while exhausting the chamber. For details on changing exhaust rate while exhausting the chamber, see "**Exhaust % during the Valve Opening Variable Exhaust Cycle**" on page 24.

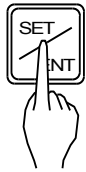

- Press the **SET/ENT** switch.
 - The display of the set sterilization (dissolution) temperature will blink indicating that the value is now changeable.

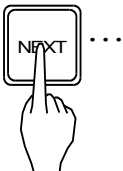

- Press the **NEXT** switch to select an item to change.
 - Each time the switch is pressed, the item to set will change in the sequence shown below.

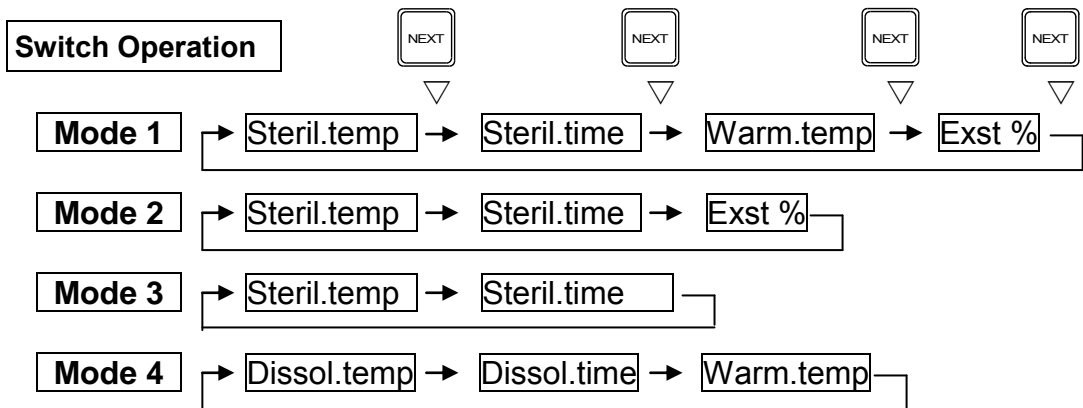

- Change the displayed value using the setting increase/decrease switches (**▲**, **▼**).
 - Each time the switches are pressed, the displayed value increases or decreases as follows:

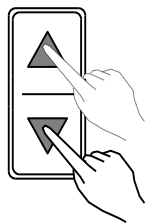

Sterilization temperature: (In increments of 1°C within a range of:)

HV-25: 105~126°C

HV-50: 105~135°C

HV-85: 105~135°C

HV-110: 105~135°C

Sterilization time : 1 min. increments within a range of 1~250 min.

Dissolution temp. : In increments of 1°C within a range of 60 ~ 100°C.

Dissolution time : 1 min. increments within a range of 1~60 min.

Warming temp. : 1°C increments within a range of 45~60°C

Exhaust % : 1 % increments within a range of 0~100 %



- If you hold the switch down, the displayed value increases or decreases in 10 unit increments. When the displayed value exceeds the upper limit (lower limit), it returns to the lower limit (upper limit).

- Press the **SET/ENT** switch.
 - The changed value is stored and the display stops blinking and lights up. This completes the setting operation.



Canceling Setting Value Changes

- To cancel setting changes during the change operation, press the **MODE** switch. The changed values will not be stored and the equipment will return to the standby state.

NOTE:

- For sterilization of liquid, set a sterilization time longer than desired, taking delay time into account and referring to the table below.

Example) In case there is 3 liters of water in a flask, it takes nearly 30 minutes (delay time) for temperature of water in the container to reach a set sterilization temperature after temperature in the chamber reaches the set value. You should set a sterilization time 30 minutes longer than desired to cope with this delay of time. Therefore, the set sterilization is 50 minutes:

Set sterilization time (50 minutes)
= Delay time (30 minutes) + desired sterilization time (20 minutes)

HV-50 Reference Values of Delay Time (per Flask)

Liquid Volume	Delay Time
3 liters	30 minutes
2 liters	25 minutes
1 liter	20 minutes
500 cc	15 minutes

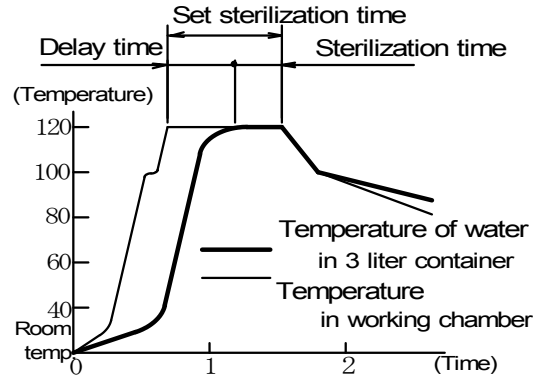

HV-50 Delay Time Reference Data

- If steam is abruptly exhausted after sterilization of liquid, the liquid may gush out. To prevent this, set the opening of the exhaust valve (Exhaust %) to a small value to gradually exhaust. Or, set that to 0 % (natural cooling).
- When used with a sterilization can, it takes several hours for the temperature in waste disposal bag to reach the set temperature after the temperature in the chamber (displayed temperature) reaches the set value (time lag).
- If there is approx. 300 ~ 500 milliliters of water in the waste disposal bag, steam is generated in the bag and drives the air out. This will significantly reduce the time lag at the time of temperature rise. Refer to the table below and take this time lag into account when setting the fertilization time.

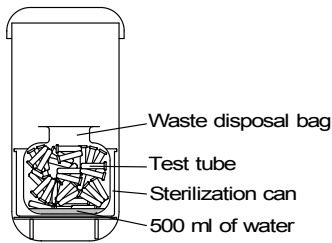

Model: HV-110

Case: A large number of 15 x 100 test tubes placed in a waste disposal bag.

HV-110 Reference Values for Time Lag in Bag

Water in Bag	Time Lag
Not poured	206 minutes
Poured	48 minutes

- For dissolution of coagulated agar medium, set an appropriate dissolution temperature and time, referring to the table below.

HV-50 Reference Values (per Flask)

Quantity of Liquid	Dissolution Temperature	Dissolution Time
2 liters	100°C	60 minutes
1 liter		45 minutes
500 cc		25 minutes

- Mode, temperature, time and opening of exhaust valve remain in the memory by means of the backup battery even after the power switch is turned off. When the backup battery has run down, the **CLOCK** display blinks, and the initial set values for Mode 1, described in the previous section, come back on display. In this case, call our authorized distributor in your region.

6. Checking and Correcting the Clock Time



- ① With the equipment in a standby state, press the **FUNC.** switch twice.
 - The **CLOCK** display lights up, and the current time appears on the digital displays.
- ② Check to see that the displayed time is correct.
 - If the time is correct: Press the **MODE** switch. (Returns to a standby)
 - If the time is incorrect: Go to ③.

- ③ Press the **SET/ENT** switch.
 - The **MONTH** display starts blinking. This indicates that the clock is now ready for correction.

- ④ Press the **NEXT** switch to select the item the setting of which you wish to change.

- Each time you press the switches, the changeable set items change repeatedly as follows:

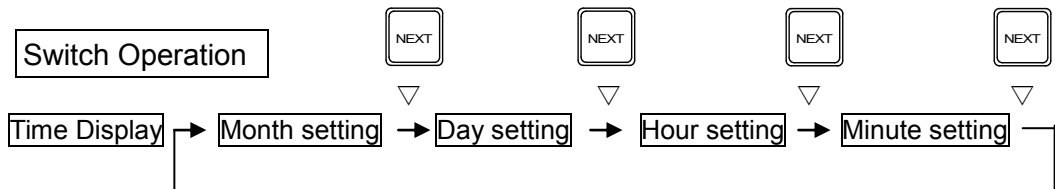

- ⑤ Change the displayed value using the setting increase/decrease switches (**▲**, **▼**).

- Each time you press the switches, the displayed value increases or decreases as follows:

Month setting:	1 month increments within a range of 1 ~ 12
Day setting:	1 day increments within a range of 1 ~ 31
Hour setting:	1 hour increments within a range of 0 ~ 23
Minutes setting:	1 minute increments within a range of 0 ~ 59

- If you hold the switches down, the displayed value increases or decreases in increments of 10 units. When the displayed value exceeds the upper limit (lower limit), it returns to the lower limit (upper limit).

- ⑥ Press the **SET/ENT** switch.

- The corrected current time is stored, and the equipment returns to a standby.

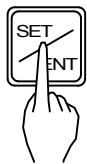
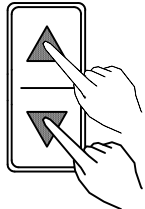
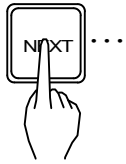
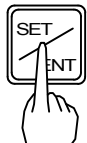

Canceling Correcting Clock

- If halfway you desire to cancel correction of the clock, press the **MODE** switch. The changed current time is not stored, and the equipment returns to a standby state.

NOTE:

- The clock continues working by means of a backup battery even after the power switch is turned off. When the backup battery has run down, the **CLOCK** display blinks. In this case, call us our authorized distributor in your region.

7. Checking and Setting of Turn-on Timer

! IMPORTANT

- In valid setting of the turn-on timer and an incorrect clock may lead to equipment malfunctions. Be sure to check the clock and correct it if necessary before setting the turn-on timer.



- ① With the equipment in a standby state, press the **FUNC.** switch once.
 - The **TIMER** display lights up, and the default value of the turn-on timer (the initial set value of operation start time) will appear on the digital display.



- ② Press the **SET/ENT** switch, and the day(s)-later display starts blinking. This indicates that it is now ready to be changed.



- ③ Press the **NEXT** switch to select the item you wish to change the setting of.
 - Each time you press the switches, the changeable set items change repeatedly as follows:

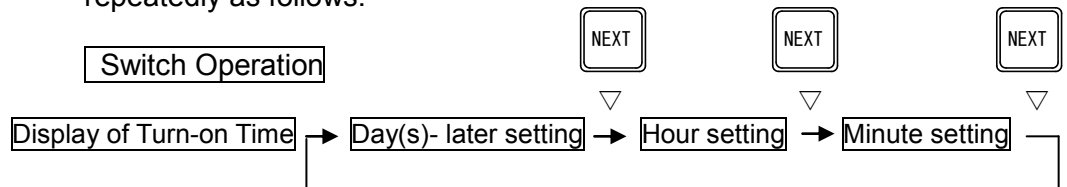

- ④ Change the displayed value using the **setting increase/decrease** switches (▲, ▼).

- Each time you press the switches, the displayed value increases or decreases as follows:
 - Day(s)-later setting:** 1 day increments within a range of 0 ~ 6
 - Hour setting:** 1 hour increments within a range of 0 ~ 23
 - Minute setting:** 1 minute increments within a range of 0 ~ 59
- If you hold down the switches, the displayed value increases or decreases in 10 unit increments. When the displayed value exceeds the upper limit (or lower limit), it returns to the lower limit (or upper limit).

Example of Setting:

When you desire to start operation at 11:30 p.m. today, your setting should be as follows: Day(s)-later setting = 0, Hour setting = 23, Minute setting = 30

When you desire to start operation at 5:00 a.m. the day after tomorrow,

your setting should be as follows:

Day(s)-later setting = 2, Hour setting = 5, Minute setting = 0

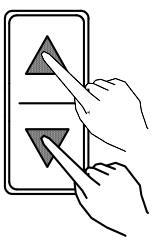

- ⑤ Press the **SET/ENT** switch.
 - The set turn-on time is stored, and the equipment returns to the standby state with the **TIMER** display on. (If you enter a time before the current time, an electronic alarm sounds and display of the day(s)-later setting starts blinking. In this case, check the turn-on time you set, and correctly set the turn-on timer again.)

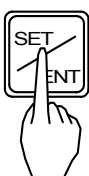

Canceling Setting Turn-on Timer

- If halfway you desire to cancel setting the turn-on timer, press the **MODE** switch. The changed turn-on time will not be stored, and the equipment returns to the standby state.



NOTE:

- Operation will not start at the set time unless the **START/STOP** switch has been pressed, even after completion of setting the turn-on timer.
- To cancel a time set on the turn-on timer, turn off the power switch, and the set turn-on time will be ignored.
- A turn-on timer setting is effective for only one operation.
- If operation is stopped before the reaching the set start time, the start time setting is kept unchanged.

8. Starting Operation

- ① Ascertain that the water level in the exhaust bottle is between the **HIGH** and **LOW** levels.
 - If above the **HIGH** level: See "**2. Draining Chamber**" on page 31.
 - If below the **LOW** level: See "**2. Installation Procedure ③**" on page 11.
- ② Ascertain that the water level in the drain bottle is low enough not to touch the tip of the exhaust hose.

[N.B.] Pour out the water from the drain bottle so that the hose tip does not touch the water.
- ③ Press the **START/STOP** switch.



- The open/close lever is locked, and the lid cannot be opened. Thereafter, the following processes are performed automatically for the selected mode. For details on each specific mode, see "**13. Operation of Cycles**" on pages 26 to 29.

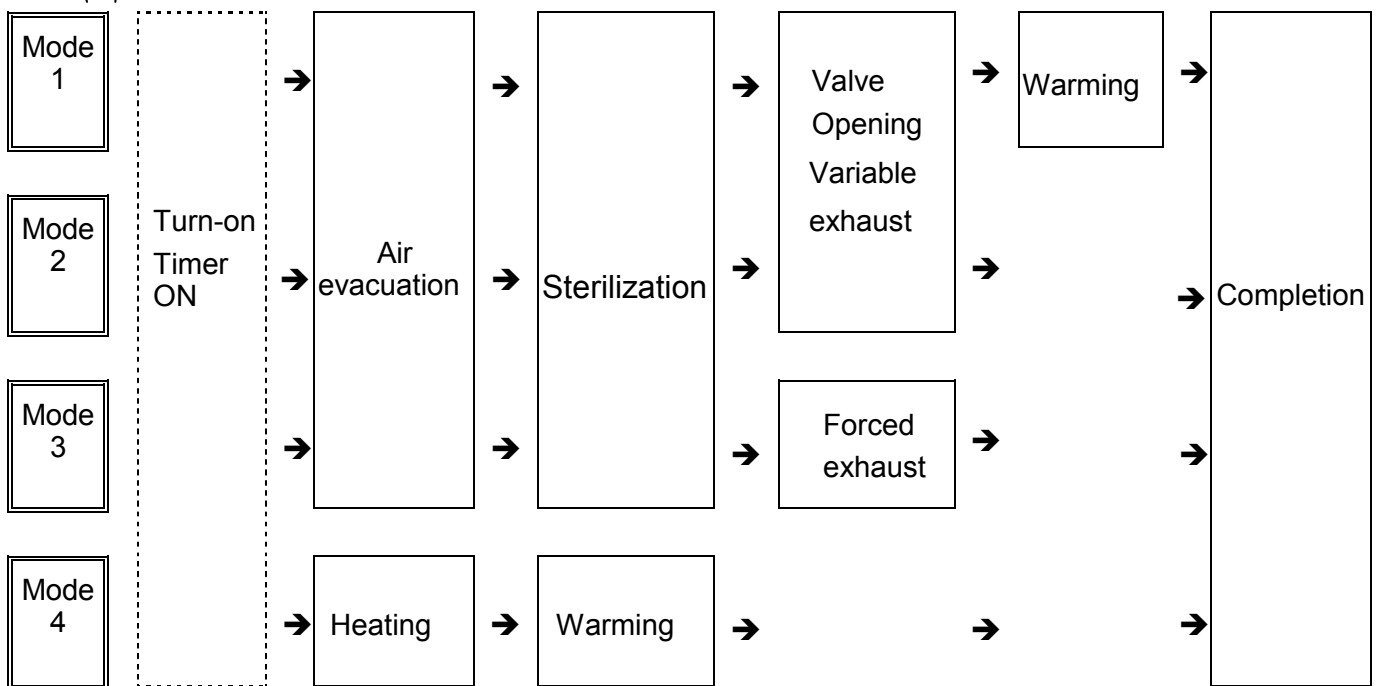

Checking Turn-on Time Setting During Turn-on Timer on Cycle

- To check the turn-on time set on the timer during the turn-on timer on cycle, press the **FUNC.** switch. While you are holding down the switch, the set time remains on the display. A set turn-on time is unchangeable.
- After the turn-on timer on cycle, the display of the turn-on time setting will read "0 day (s) later, 0 hour, 00 min.".

Checking Set Values During Operation

- To check the set values for temperature, time or opening of the exhaust valve during operation, press the **MODE** switch. While you are holding down the switch, the set value remains on display. Set values are not changeable.

Exhaust % During the Valve Opening Variable Exhaust Cycle

- ① Press the **SET/ENT** switch.
 - The display of opening of the exhaust % display starts blinking, and indicates that it is now ready to be changed.

- ② Change the numeric value using the set value **increase/decrease** switches (**▲, ▼**).
 - Each time you press the switches, the displayed value increases or decreases in 1 % increments within a range of 1-100 %.
 - If you hold down the switches, the displayed value increases or decreases in 10 % increments.
When the displayed value exceeds the upper limit (or lower limit), it returns to the lower limit (or upper limit).

- ③ Press the **SET/ENT** switch.
 - The changed value will be stored, and the display stops blinking and lights up again. The exhaust valve is controlled according to the set exhaust %. (The stored numerical value is also effective for the next operation.)

9. Unloading

WARNING:

- Confirm that the gauge for pressure in the chamber reads "0MPa".

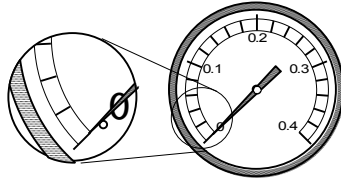

Pressure gauge

CAUTION:

- Keep the face and hands away from the chamber when lifting the lid after operations are complete; steam will gush out of the opening of the chamber.
- After operation is over, the lid, chamber, packing and panel are hot. To protect yourself from burns, do not touch with bare hands.
- It takes a lot of time for the liquid to cool. Be sure to check that the temperature has dropped sufficiently before unloading the liquid from the chamber, or you may get burned.
- Put on heat insulation gloves before taking a substance out of the chamber. Do not put your hands into the chamber until the steam has been vented.

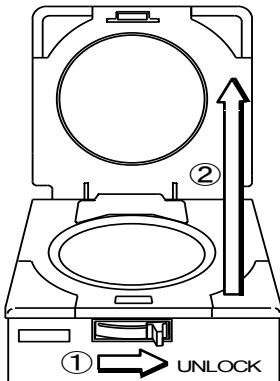

- ① Slide the open/close lever to the **UNLOCK** side (to right end).
- ② Lift the lid.
- ③ Take the sterilized substance out of the chamber.

10. After Completion of Operations

- ① Turn off the **POWER** switch after the completion of each routine operation.

IMPORTANT:

- To prevent clogging of the piping and also rusting & staining of the heater, change the water of the chamber, once a day. Without drainage of water of the chamber, if filling in the gaps and continuing to run, in case the sterilized substances is like sodium chloride, acidity or alkalinity, a part of such a substance dissolve into the pouring water and then the chamber, heater and heater cover may be corrosive.

11. To Interrupt Operation

△ NOTE :

- If operation is interrupted during the sterilization of liquid, the liquid may overflow into the chamber.



① Press the **START/STOP** switch

- The ongoing process will be interrupted, and the equipment returns to the standby state (state before operation).
- When you take the sterilized substance out of the chamber, follow the instructions described in "**9. Unloading**". (When chamber temperature drops below 97°C in the **SOLID** mode, pressure drops to 0MPa. In this state, the open/close lever can be unlocked.) (If a floating sensor is used, the sensor regulates the open/close lever by sensing the temperature.)

12. If Power Supply is Cut Off during Operation

- If power supply is shut off before completing the operation due to power failure etc, operation is interrupted and the power switch is in the off state when power supply comes back. When the POWER switch is pressed and the equipment becomes standby state, . . . is displayed in the digital display window and an electronic alarm sounds to notify it that the operation was not completed due to the power failure. This power failure notice is stored in memory and it continues to notify even if the ON /OFF operation of the POWER switch is repeated. When the START/STOP switch is pressed during the power failure notice, the display turns to the standby state (the state before operation startup). Redo the operation once again.

△ NOTE :

- If power supply is cut off due to power failure or the like, the open/close lever is locked for safety. To open or close the lid, follow the instructions described in "**9. Unloading**" on page 25 after the power supply has been restored.

13. Operation of Cycles

■ Turn-on Timer On Cycle --- Common to all the modes (with the turn-on timer set)

- The digital display section illuminate in a circular manner until the time set on the turn-on timer (preset time of operation start-up) is reached.
- When the time set on the turn-on timer is reached, the **TIMER** digital goes off, and operation proceeds to the next cycle.

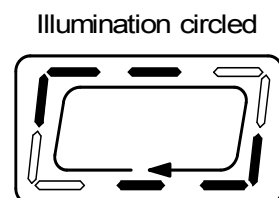

■ Air Evacuation Cycle --- Mode 1, 2 and 3

- The **ST-BY** display stops blinking and lights up; then the **HEATG** goes off and starts blinking. The temperature in the chamber is displayed in the digital temperature display section.
- Any air remaining in the chamber makes the temperature distribution in the chamber uneven. This hinders temperature rise (sterilization). To cope with this, a microcomputer-controlled automatic exhaust valve vents virtually 100 % of the air.
- Temperature rises until a set sterilization temperature (pressure) is reached.
- After the set sterilization temperature is attained, the **HEATG** stops blinking and lights up. Operation proceeds to the next step.

■ Sterilization Cycle --- Modes 1, 2 and 3

- The **STER.** display goes out and starts blinking. The set sterilization time is shown in the digital display upon activation of the sterilization timer.
- A constant temperature (pressure) is maintained during the set sterilization time period.
- If the temperature in the chamber drops 1°C or more from the set value due to any trouble, the temp. over-drop mark appears on the digital display, and the digital timer operation is interrupted. When the set temperature is regained, the timer restarts operation.
- The digital timer displays the remaining time during the sterilization cycle. Refer to "**Checking Set Values during Operation**" on page 24 for the method of checking the set time during operation.
- When the preset sterilization time has passed, the **STER.** display stops blinking and lights up, and operation proceeds to the next cycle.

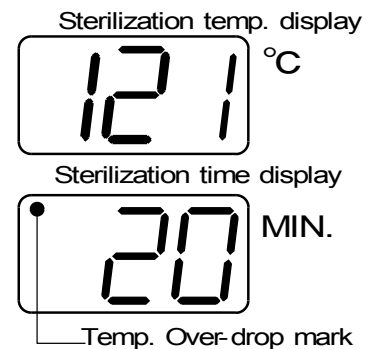

△ **NOTE :**

- In sterilization of petri dishes or empty containers, the air remaining in the container expands and may increase the pressure extraordinarily within the chamber. If the pressure in the chamber exceeds the saturated steam pressure, the automatic exhaust valve opens and discharges the air in the chamber into the exhaust bottle.

■ Valve Opening Variable Cycle --- Modes 1 and 2

- The **EXHT.** display goes out and starts blinking. The digital display indicates the exhaust % value.
- You can change the exhaust % value during the valve opening variable exhaust cycle. To do so, refer to "**Exhaust % During the Valve Opening Variable Exhaust Cycle**" on page 24.



NOTE :

- If the steam is exhausted abruptly after liquid sterilization, the liquid may gush out. To prevent this, set the exhaust % to a small value to gradually exhaust the steam. Or, set that to 0 % (spontaneous cooling).
- When the pressure in the chamber falls below 0MPa, the exhaust valve is fully opened.
 - When the temperature in the chamber (or the temperature registered by the floating sensor, if used) falls to 97°C, the **EXHT.** display stops blinking and lights up. The display of opening of the exhaust valve (exhaust %) disappears from the digital display, and operation proceeds to the next cycle.

■ Forced Exhaust Cycle --- Mode 3

- The **EXHT.** display goes out and starts blinking, and the automatic exhaust valve is fully opened.
- When the temperature in the chamber falls to 97°C, the **EXHT.** display stops blinking and lights up, and operation proceeds to the next cycle.

■ Dissolution of Agar --- Mode 4

- The **ST-BY** display stops blinking and lights up, and the **HEATG** display goes out and starts blinking. The digital display indicates the temperature in the chamber.
- Temperature rises until a set dissolution temperature is reached.
- After the set temperature is reached, a set dissolution time is shown on the digital display upon the activation of the dissolution timer.
- The digital timer displays the remaining time during the heating cycle. Refer to "**Checking Set Values during Operation**" on page 23 for the method of checking the set time during operation.
- When the time preset for dissolution has passed, the **HEATING LED** stops blinking and lights up, and operation proceeds to the next cycle.

■ Warming Cycle --- Modes 1 and 4

- The **WARM** display goes out and blinking.
- When the temperature in the chamber falls to a set incubation temperature, the electronic alarm gives a beeping sound.
- When 20 hr. (fixed) have passed after the temperature drops to the set incubation temperature, the **WARM** display stops blinking and lights up, and operation proceeds to the next cycle.

△ **NOTE :**

- After the warming time (20 hr.) has passed, the chamber is not heated; temperature in the chamber falls to room temperature, and the remaining agar media, if any, in the chamber will be coagulated.
- When you take a sterilized substance out of the chamber during the warming cycle, press the **START/STOP** switch to stop operation. Refer to "**9. Unloading**" on page 25.

■ Completion Cycle --- Common to all the Modes

- When all cycles of each mode are complete, the electronic alarm indicates completion of all cycles by giving a beeping sound three times. Then the **COMP.** display goes out and starts blinking.

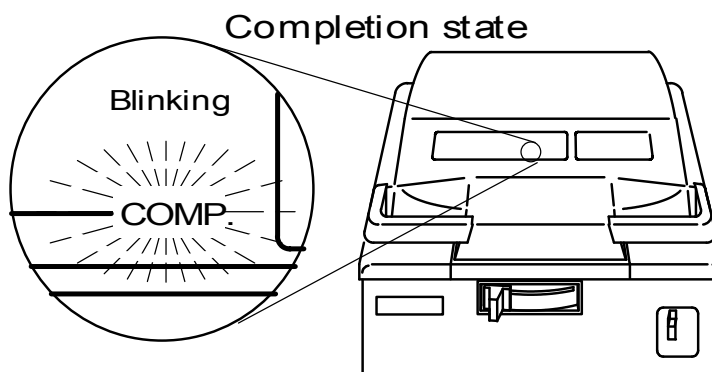

△ **NOTE:**

- If the operation switches and the lock / unlock lever are left un-operated for 30 minutes, the power saving function starts to work so that the display board blackens except for dots blinking at the temperature zone. For reviving the display, please press any of the operation switches.

Chapter 4. Maintenance and Service

! **WARNING:**

- Be sure to start maintenance or service work after the main body has been sufficiently cooled.

1. Draining Exhaust Bottle

Water collects in the exhaust bottle as operations are repeated. If the water is above the **HIGH** level (allowable highest water level), drain the bottle in accordance with the following procedures.

! **CAUTION:**

- Do not unload the exhaust bottle before water in the bottle has been sufficiently cooled.

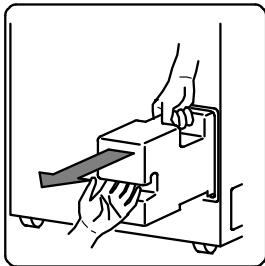

① Remove the exhaust bottle from the body.

- Pull the bottle outward until the top handle can be grabbed securely.

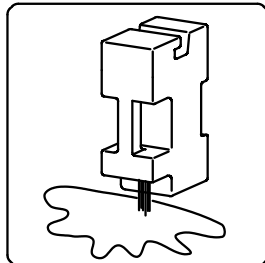

② Place the bottle in a level sink with the water filling and drain ports facing downwards.

- Excessive water is drained automatically until the water level is lowered to the **LOW** level (lowest allowable water level).

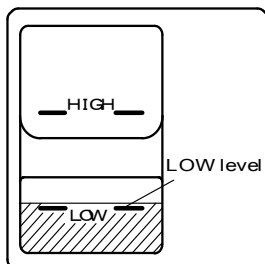

③ Be sure that the water level is at **LOW** level.

- Ensure that water is left at the **LOW** level (lowest allowable level), which is required for sufficiently cooling the steam.

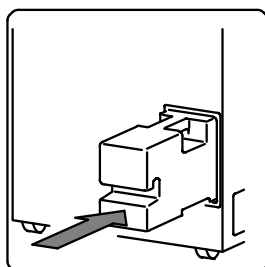

④ Loading the exhaust bottle into the bottle housing area.

- Be sure to push the bottle to the end, or else an error (**ErE**) will occur.

2. Draining Chamber

- When planning to put the equipment out of service for a long time, be sure to drain the chamber to prevent pipe clogging. After checking that the chamber has been sufficiently cooled, drain the chamber in accordance with the following procedure.

! CAUTION :

- Do not unload the exhaust bottle or drain the chamber when the chamber is under pressure. Boiling water or steam may gush out causing burns.

- ① Open the lid.
- ② Connect one end of the attached drain hose to the tap of the drain valve located at the lower part of the right side of the body.
- ③ Put the other end of the hose in a container.
- ④ Remove the exhaust bottle from the body.
- ⑤ Turn the drain valve knob, located at the bottom of the exhaust bottle housing area, counterclockwise to open.
- ⑥ Check if draining of the chamber is complete.
- ⑦ Turn the knob clockwise to close the drain valve.
 - Be sure the exhaust valve is closed.

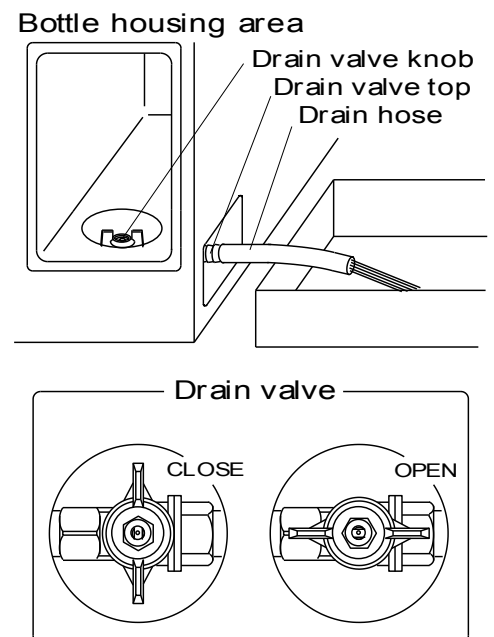

3. Cleaning Chamber

! CAUTION :

- The heater is provided with a temperature sensor, be careful not to damage this sensor when cleaning.

- ① Take out the bottom plate to see if the bottom of the chamber or the surface of the heater is dirty. After draining the chamber, clean these areas with a soft brush or other tool while applying water and keeping the drain valve open.
- ② If the temperature sensor comes loose from the fixing clip, reattach it.

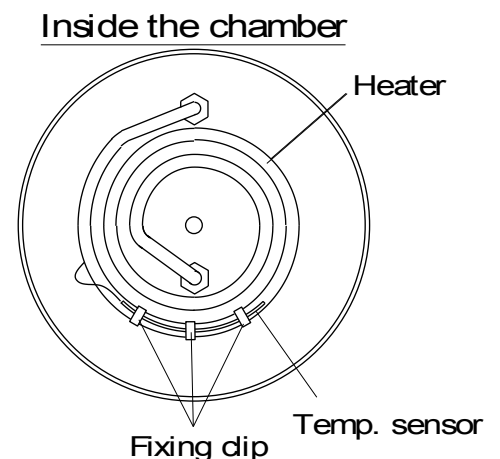

4. Cleaning Body



IMPORTANT :

- Do not use benzine or thinner to clean the body. Also make sure that the volatile substances such as insecticides do not come into contact with the body as these substances may deteriorate the body or strip its paint.
-
- ① Gently wipe stains from the body with a soft cloth. To remove stubborn stains, wring a cloth moistened with neutral detergent diluted with water, and wipe off the stains with it. Wipe off any moisture with a dry cloth.

Chapter 5. Specifications

Model	HV-25	HV-50
Outer dimensions	480W × 950H × 460D mm*	540W × 1040H × 530D mm*
Chamber size	240Ø x 550D mm (Effective: 25□)	300Ø x 710D mm (Effective: 50□)
Power source	AC110V±10% 1Φ 50/60Hz (14A or more) AC120V±10% 1Φ 50/60Hz (13A or more) AC220V±10% 1Φ 50/60Hz (7A or more) AC230V±10% 1Φ 50/60Hz (7A or more) AC240V±10% 1Φ 50/60Hz (7A or more)	AC110V±10% 1Φ 50/60Hz (13A or more) AC120V±10% 1Φ 50/60Hz (17A or more) AC220V±10% 1Φ 50/60Hz (10A or more) AC230V±10% 1Φ 50/60Hz (9A or more) AC240V±10% 1Φ 50/60Hz (9A or more)
Utility conditions	5 ~ 35°C, 10 ~ 85%RH (Subject to, no condensation)	
Power consumption	1.5KW (110V/13.7A, 120V/12.5A, 220V/6.8A, 230V/6.6A, 240V/6.3A)	2.0KW (110V/19A, 120V/6.7A, 220V/9.1A, 230V/8.7A, 240V/8.4A)
Net Weight(approx.)	41kg	57kg
Pressure vessel type	Miniature pressure vessel	Small sized pressure vessel
Chamber material	Stainless Steel (SUS304)	
Sterilization temp. range	105~126°C variable	105~135°C variable
Sterilization timer	1~250 minutes, Remaining time displayed	
Dissolution temp. range	60 ~ 100°C variable	
Dissolution timer	1~60 minutes, Remaining time displayed	
Warming temp. range	45 ~ 60°C variable	
Exhaust valve open. range	0 ~ 100 % variable	
Turn-on timer	1 min. ~ 1 week later. Start-up time to be set.	
Max. allowable pressure	0.186MPa	0.255MPa
Thermometer display range	Digital display, 5 ~128°C	Digital display, 5 ~ 137°C
Clock	24-hour system. Date and time of day alternately displayed.	
Pressure gauge	Analog display, 0 ~ 0.4MPa	
Backup battery life	Approx. 5 years.	
Safety devices/ Warning alarm	Pressure safety valve, Circuit breaker, Lack-of-water prevention device, Error display (Lack-of-water, Temperature sensor wire breakage, Over temperature, Over cooling, Overpressure, Open/close lever locking failure)	
Standard accessories	Exhaust bottle (1 pc) Heater cover (1 pc) Drain hose 50 cm (1 pc) Exhaust hose 50 cm (1 pc) Drain bottle (1 pc), Strap (1 pc) Operation manual (1 pc) Caster stoppers (2 pcs)	Exhaust bottle (1 pc) Heater cover (1 pc) Drain hose 50 cm (1pc) Exhaust hose 50 cm (1pc) Drain bottle (1 pc), Strap (1 pc) Operation manual (1 pc) Caster stoppers (2 pcs)

* D mm size is not including the Lid Open/Close lever.

Model	HV-85	HV-110
Outer dimensions	660W × 1000H × 650D mm*	660W × 1180H × 650D mm*
Chamber size	420Ø x 615D mm (Effective: 85□)	420Ø x 795D mm (Effective: 110□)
Power source	AC110V ± 10% 1Φ 50/60Hz (28A or more) AC120V ± 10% 1Φ 50/60Hz (26A or more) AC220V ± 10% 1Φ 50/60Hz (14A or more) AC230V ± 10% 1Φ 50/60Hz (14A or more) AC240V ± 10% 1Φ 50/60Hz (13A or more)	AC110V ± 10% 1Φ 50/60Hz (37A or more) AC120V ± 10% 1Φ 50/60Hz (34A or more) AC220V ± 10% 1Φ 50/60Hz (19A or more) AC230V ± 10% 1Φ 50/60Hz (18A or more) AC240V ± 10% 1Φ 50/60Hz (17A or more)
Utility conditions	5 ~ 35°C, 10 ~ 85%RH (No condensation)	
Power consumption	3.0KW (110V/27.3A, 120V/25A, 220V/13.6A, 230V/13.1A, 240V/12.5A)	4.0KW (110V/36.4A, 120V/33.4A, 220V/18.2A, 230V/17.4A, 240V/16.7A)
Net weight (approx.)	71kg	81kg
Type of pressure vessel	Small sized pressure vessel	
Material of chamber	Stainless Steel (SUS304)	
Sterilization temp. range	105 ~ 135°C variable	
Sterilization timer	1 ~ 250 minutes, Remaining time displayed	
Dissolution temp. range	60 ~ 100°C variable	
Dissolution timer	1 ~ 60 minutes, Remaining time displayed	
Warming temp. range	45 ~ 60°C variable	
Exhaust valve open. range	0 ~ 100 % variable	
Turn-on timer	1 min. ~ 1 week later. Start-up time to be set.	
Max. allowable pressure	0.255MPa	
Thermometer display range	Digital display 5 ~ 137°C	
Clock	24-hour system. Date and time of day alternately displayed.	
Pressure gauge	Analog display, 0~0.4MPa	
Backup battery life	Approx. 5 years.	
Safety devices/ Warning alarm	Pressure safety valve, Circuit breaker, Lack-of-water prevention device, Error display (Lack-of-water, Temperature sensor wire breakage, Over temperature, Over cooling, Overpressure, Open/close lever locking failure)	
Accessories	Exhaust bottle (1 pc) Heater cover (1 pc) Drain hose 50 cm (1pc) Exhaust hose 50 cm (1pc) Drain bottle (1 pc) , Strap (1 pc) Operation manual (1 pc) Caster stoppers (2 pcs)	

* D mm size is not including the Lid Open/Close lever.

Chapter 6. Troubleshooting

1. Error Detection (Alarms)

- Should any malfunction occur in the autoclave, the error detection circuit will be triggered to assure safety. Once the circuit is activated, an error number appears on the digital display and the electronic alarm sounds, indicating the problem. To stop the alarm sound, press the **START/STOP** switch. If an alarm occurs, check the error number and turn off the power switch.

Error Number	Problem	Remedy
E r 1 (Lack-of-water alarm)	<ul style="list-style-type: none"> • Lack-of-water 	<ul style="list-style-type: none"> • Check to see that the pressure is at 0 MPa and then open the lid. After the heater has been cooled, pour in a sufficient quantity of water, and repeat operations from the beginning.
	<ul style="list-style-type: none"> • Piping is clogged by a bag such as the waste disposal bag. 	<ul style="list-style-type: none"> • Whenever a bag, such as a waste disposal bag, is used for sterilization. put it in the wire mesh basket and place the basket in the working chamber.
E r 2 (Temperature sensor wire breakage)	<ul style="list-style-type: none"> • Temperature in the working chamber falls below the freezing point. 	<ul style="list-style-type: none"> • Adjust room temperature at the installation site to 5 ~ 35°C.
	<ul style="list-style-type: none"> • Disconnection of temperature sensor for control. 	<ul style="list-style-type: none"> • Contact our authorized distributor in your region.
E r 3 (Over temperature alarm)	<ul style="list-style-type: none"> • Temperature in the working chamber exceeded the upper limit of the working temperature range by + 3°C or more. • A temperature + 5°C or more above the set temperature continued for 10 seconds during sterilization. • A temperature +10°C or more above the set temperature continued for 15 minutes during warming. 	
E r 4 (Over- cool alarm)	<ul style="list-style-type: none"> • A temperature of 102°C or less continued for 10 seconds during sterilization. 	

Error Number	Problem	Remedy
Er 5 (Over- pressure alarm)	<ul style="list-style-type: none"> The pressure of the saturated steam pressure at a set temperature + 0.025 MPa or above continued in the working chamber for 30 seconds. 	<ul style="list-style-type: none"> Contact our authorized distributor in your region.
	<ul style="list-style-type: none"> Piping is clogged by a bag such as the waste disposal bag. 	<ul style="list-style-type: none"> Whenever a bag, such as a waste disposal bag, is used for sterilization, put it in the wire mesh basket and place the basket in the working chamber.
Er 6 (Lid open alarm)	<ul style="list-style-type: none"> The open/close lever was moved to the UNLOCK side during operation. 	<ul style="list-style-type: none"> Contact our authorized distributor in your region.
Er 7 (Automatic exhaust valve trouble alarm)	<ul style="list-style-type: none"> The automatic exhaust valve continued closing operation for 30 seconds. 	
Er 9 (Sterilization heater trouble alarm)	<ul style="list-style-type: none"> Temperature in the working chamber has not reached a set sterilization temperature after 4 hours has elapsed from operation start-up. 	<ul style="list-style-type: none"> Reduce the quantity of substance to be sterilized and repeat operations from the beginning. If this error reoccurs after all measures have been taken, contact our authorized distributor in your region.
Er L (Open/close level locking failure alarm)	<ul style="list-style-type: none"> The open/close lever is unlocked during operation. 	<ul style="list-style-type: none"> Contact our authorized distributor in your region. When contacting the distributor, be sure to have model and serial number information.
Er E (Exhaust bottle anomaly alarm)	<ul style="list-style-type: none"> The exhaust bottle has moved out of place during operation. 	<ul style="list-style-type: none"> Push the exhaust bottle into the housing area as far as it will go and repeat operations from the beginning.
Er □ (Power failure alarm)	<ul style="list-style-type: none"> When power supply is shut off during operation 	<ul style="list-style-type: none"> Redo the operation from the beginning.

2. Early Troubleshooting

Symptom	Cause	Remedy
Display remains off after power is turned on.	<ul style="list-style-type: none"> • Check the plug and outlet first. (1) The plug is not properly inserted or is insufficiently tightened. (2) Disconnection in the power cord. (3) Defect in the DISPLAY. 	<ul style="list-style-type: none"> (1) Properly insert the plug and retighten any loose parts. (2)(3) Contact our authorized distributor in your region.
No air exhausted from the working chamber.	<ul style="list-style-type: none"> (1) Defective automatic exhaust valve. 	<ul style="list-style-type: none"> (1) Contact our authorized distributor in your region.
Pressure gauge reading remains low.	<ul style="list-style-type: none"> (1) Defective safety valve. (2) Defective pressure gauge. (3) Disconnection in the heater. (4) Defective automatic exhaust valve (5) Steam leakage. 	<ul style="list-style-type: none"> (1)-(4) Replace the defective part (Contact our authorized distributor in your region). (5) For steam leakage from piping, retighten or seal joints.
Steam leakage from lid gasket	<ul style="list-style-type: none"> (1) Deterioration of lid gasket (2) Improperly installed lid gasket. (3) Foreign matter under the gasket. 	<ul style="list-style-type: none"> (1) Replace the lid gasket. (2) Press on the gasket to remove any unevenness. (3) Remove the foreign matter.
Water leakage from the bottom of the body.	<ul style="list-style-type: none"> (1) Deterioration of the heater seal packing due to lack of water or other problem. (2) The drain valve open. 	<ul style="list-style-type: none"> (1) Contact our authorized distributor in your region. (2) Close the valve.
Open/close lever cannot slide	<ul style="list-style-type: none"> (1) Temperature in the working chamber has exceeded 80°C in the SOLID mode, or the pressure has exceeded 0.01Mpa. (2) The power switch is off. 	<ul style="list-style-type: none"> (1) Wait until the temperature in the working pressure falls below 97°C in the SOLID mode and the pressure is reduced to 0MPa. (2) Turn on the Power ON/OFF switch.
Lid cannot be opened or closed	<ul style="list-style-type: none"> (1) The open/close lever has not slid completely to the UNLOCK side. 	<ul style="list-style-type: none"> (1) Slide the lever completely to the UNLOCK side.
Displayed temperature exceeds set temperature and exhaust is repeated frequently during the sterilization cycle.	<ul style="list-style-type: none"> (1) Defect in the heater circuit. 	<ul style="list-style-type: none"> (1) Contact our authorized distributor in your region.

● This table of early troubleshooting describes the causes and remedies of simple problems. If you are unable to fix or repair the problem, Contact our authorized distributor in your region and provide the following information.

- (1) Model and serial number of the autoclave.
- (2) Defective point(s) and symptom(s) (error number if applicable).
- (3) Number of days of operation (date of purchase).
- (4) Operating conditions (including substances being sterilized).

SPARE PARTS FOR HV-SERIES AUTOCLAVES

<u>Catalog No.</u>	<u>Description</u>
ATA-25LG	Lid gasket for HV-25
ATA-50LG	Lid gasket for HV-50
ATA-85LG	Lid gasket for HV-85 and HV-110
ATA-25H	Heater for HV-25 (specify 120V or 220V)
ATA-50H	Heater for HV-50 (specify 120V or 220V)
ATA-85H	Heater for HV-85
ATA-110H	Heater for HV-110
ATA-HVEGO	Low water power cut-off devise, includes sensor and thermostat for HV autoclaves
ATA-HVLSA	Lid solenoid assembly for HV autoclaves, 24V
ATA-HVMVA	Motor valve assembly, including condenser & limit switch for HV autoclaves
ATA-ROM	ROM including extractor for HV autoclaves
ATA-HVPB	Plastic exhaust bottle for HV autoclaves
ATA-HVSSR	Solid state relay for HV autoclaves
ATA-HVTS	Temperature sensor for HV autoclaves
ATA-TRTP	Thermal paper for digital recorder, 9 rolls
ATA-TRTP4	Thermal paper for digital recorder, 4 rolls

If you need technical support, have any concerns or questions, or would like to place an order for spare parts, please contact:



Amerex Instruments, Inc.

3951C Industrial Way
 Concord, CA 94520 USA
 (925) 299-0743 / (888) 263-7392
 Fax: (925) 299-0745
marketing@amerexinst.com